

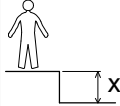

N°		
1	<0.6 m	17 m ²

— Zone d'impact
Impact area
Area de impacto
Fallraum
Valzone

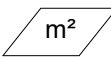

Point de référence
Setting out point
Punto de referencia
Bezugspunkt
Referentiepunt

- - - Espace libre
Free space
Espacio libre
Freiraum
Vrije ruimte

EN1176-1:2017

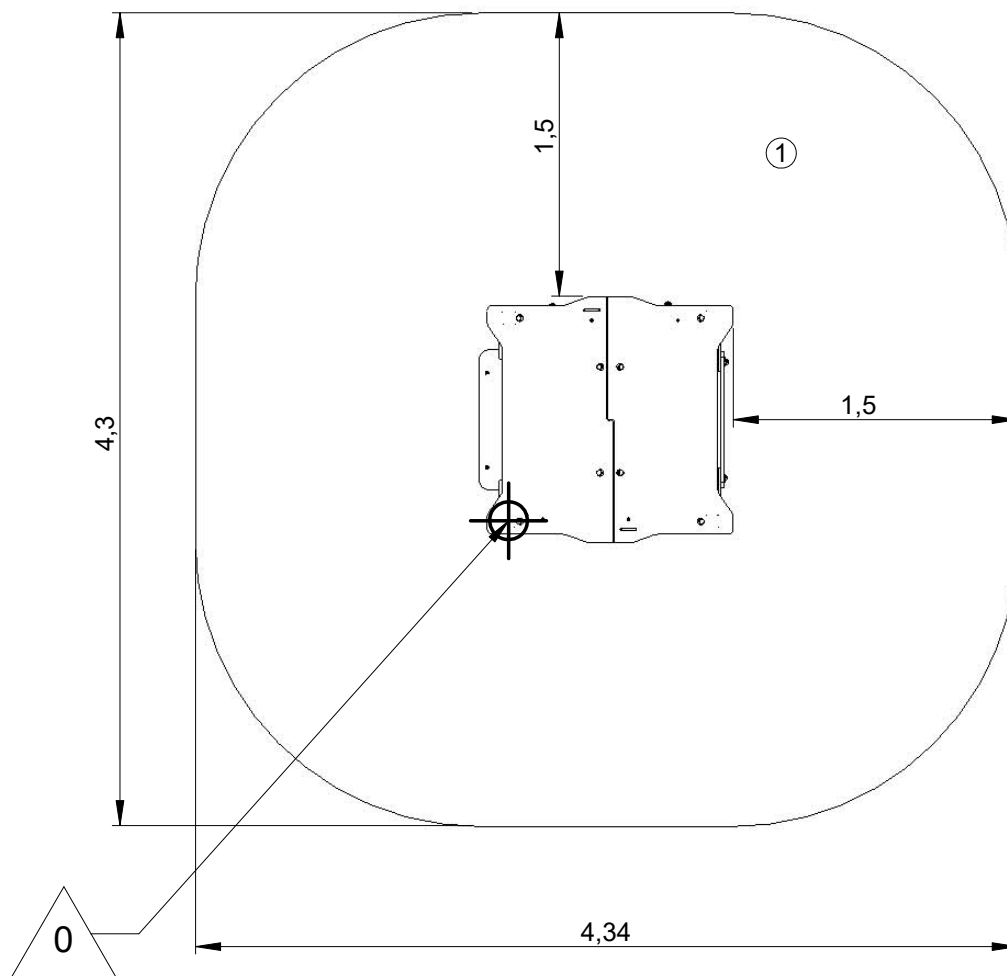

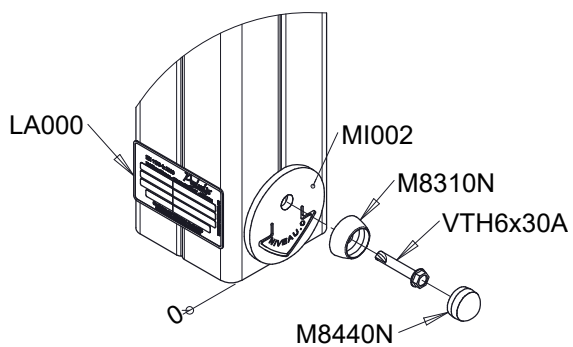
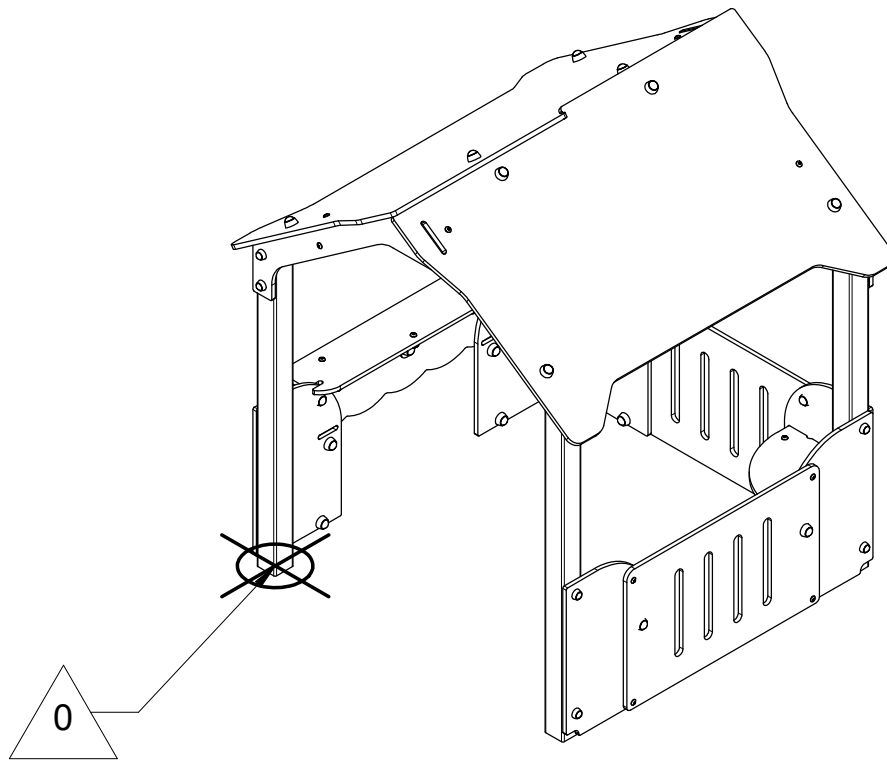

Réf	Qté
G250A	1
G253	2
G256	1
G262	1

— Zone d'impact
 Impact area
 Area de impacto
 Fallraum
 Valzone

17 m²

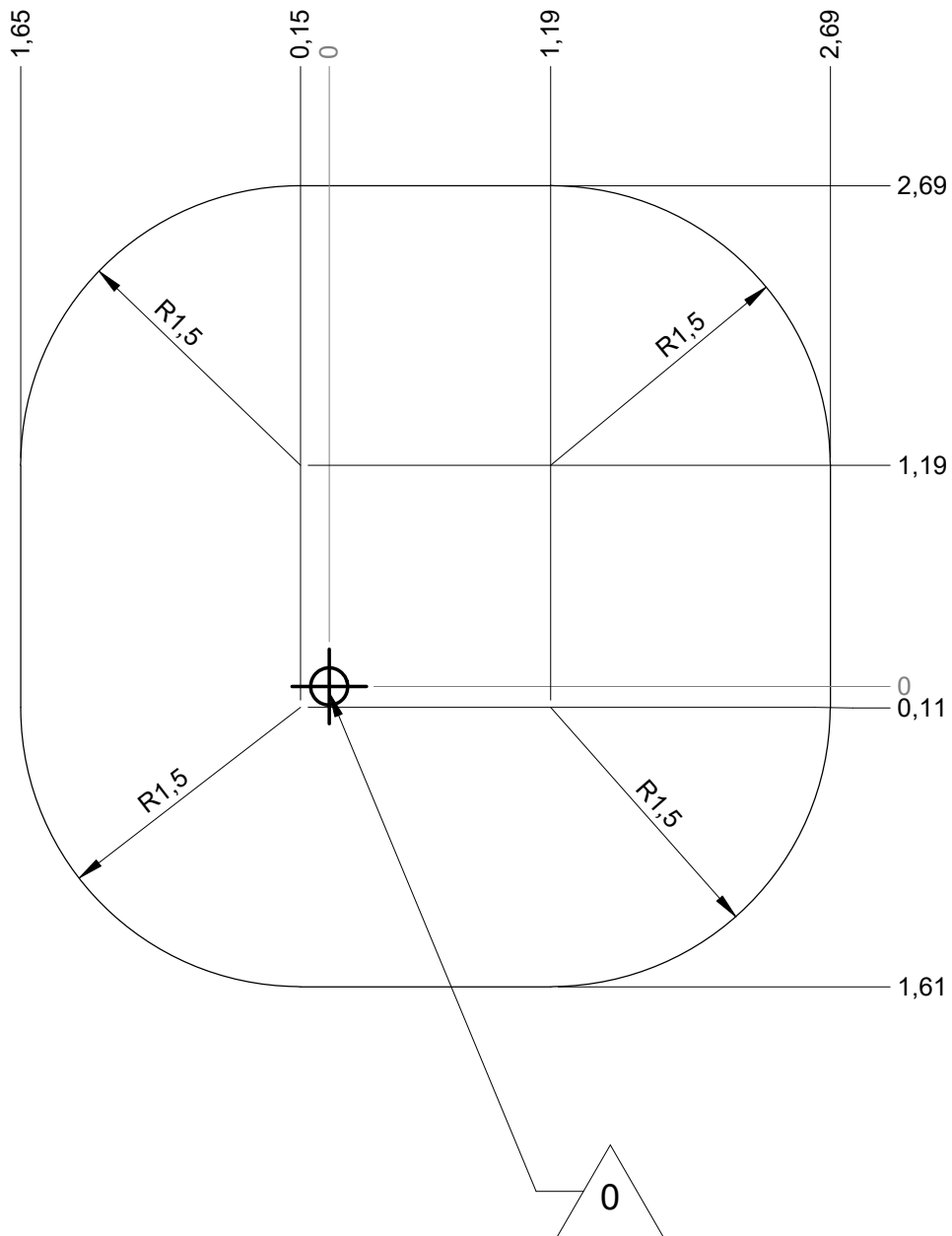

— Sol souple
Wetpour
Caucho continuo
Synthetischer Fallschutz
Gietvloer

17 m²

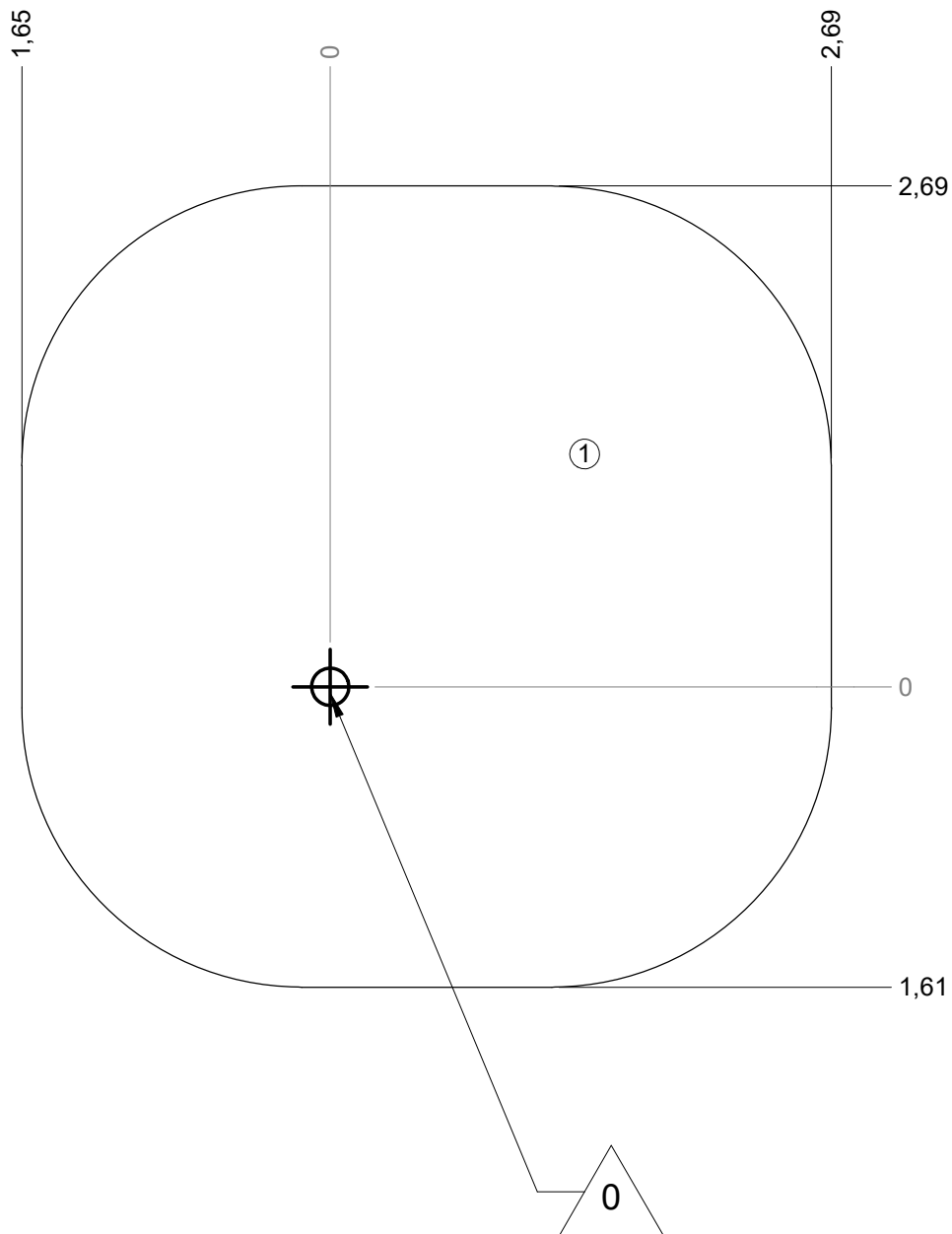

— Dalle béton
Concrete pad
Solera de hormigon
Beton Bodenplatte
Betonnen bodemplaat

18 m
19 m²

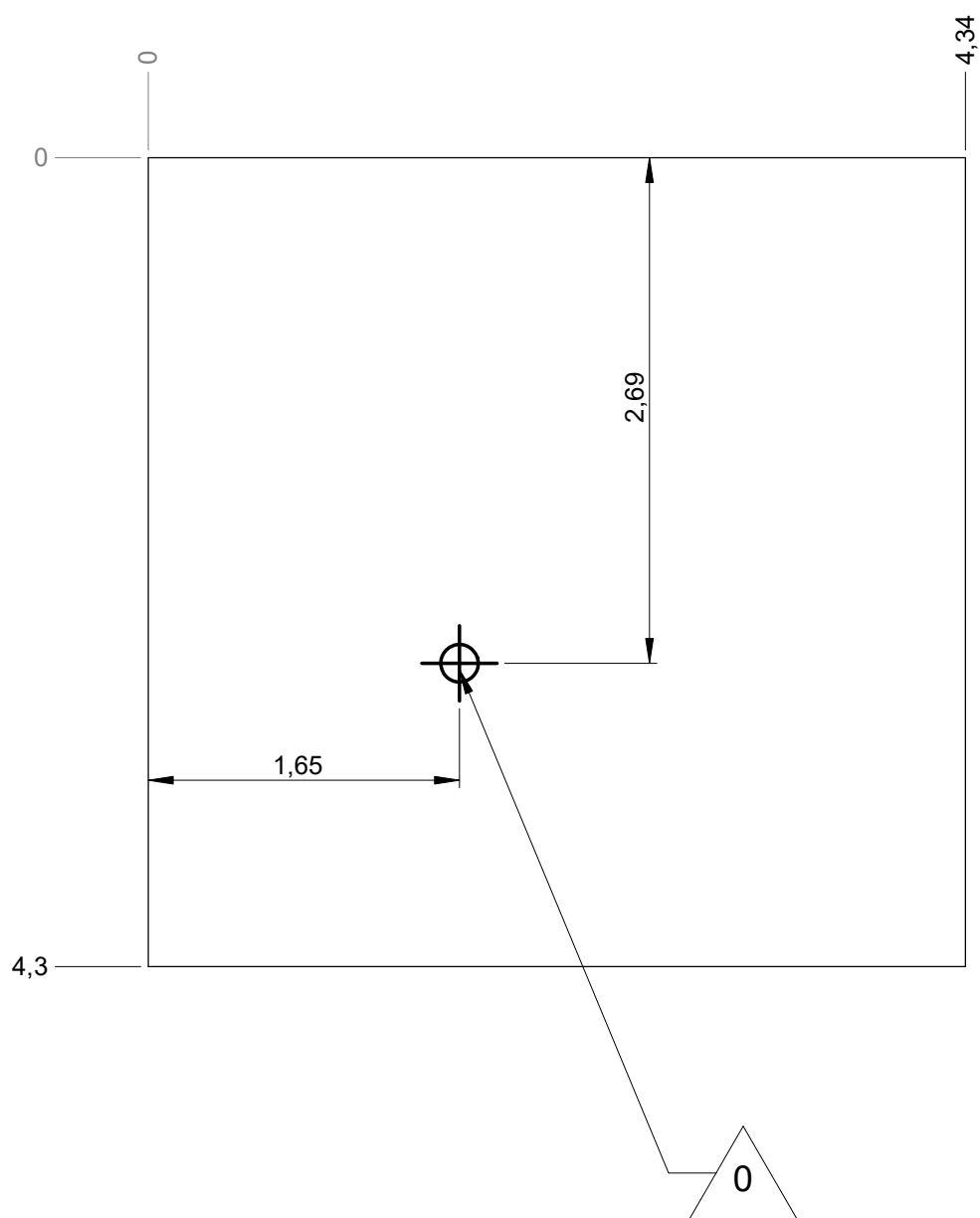

— Sol fluent
Loos partucule material 19 m
Arenero
Loses Bodenmaterial 21 m²
Los bodemmaterial

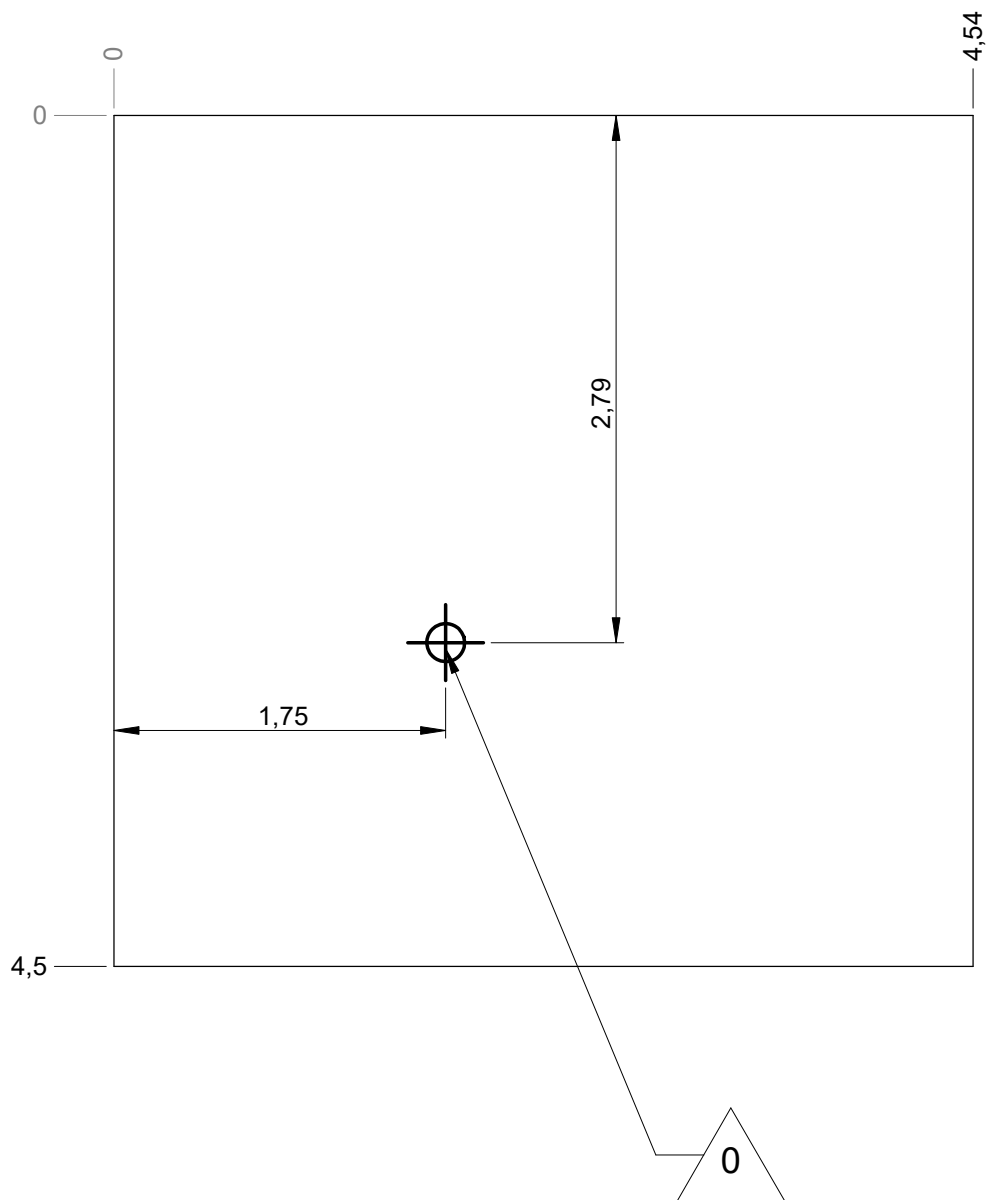

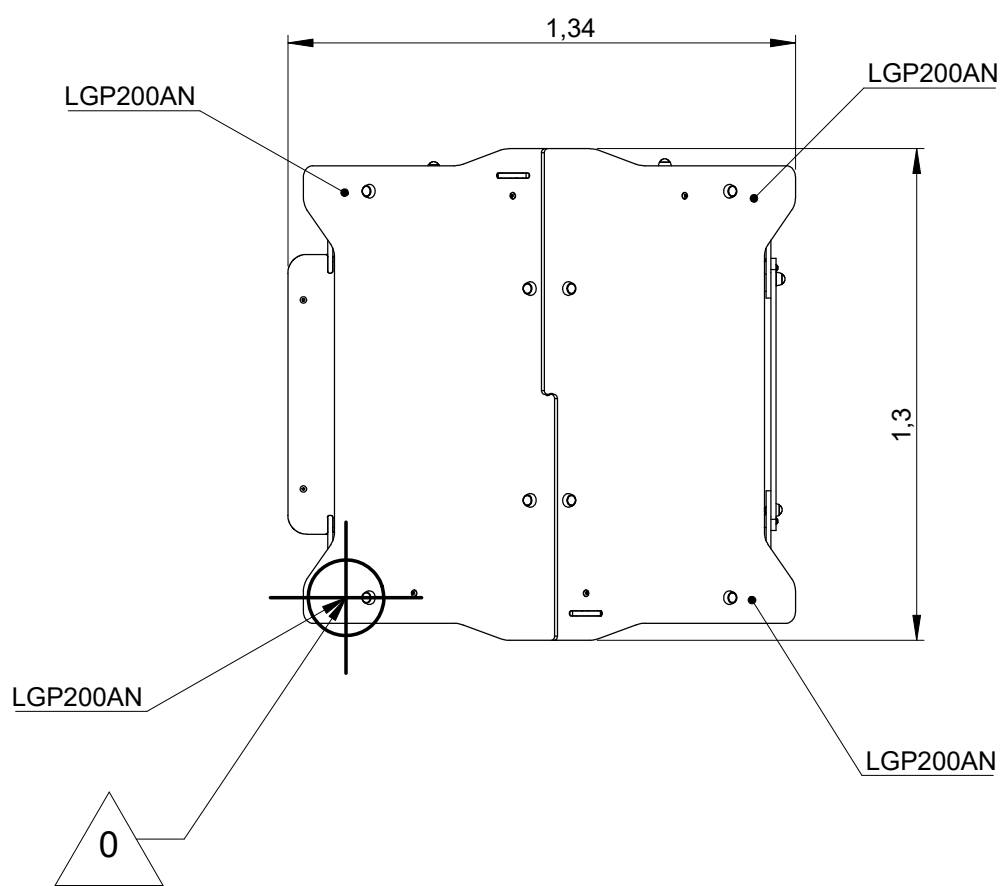

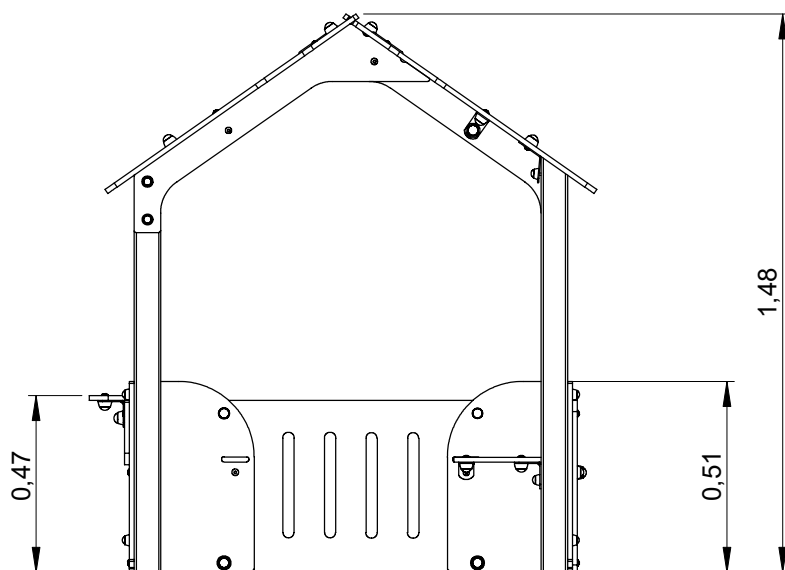



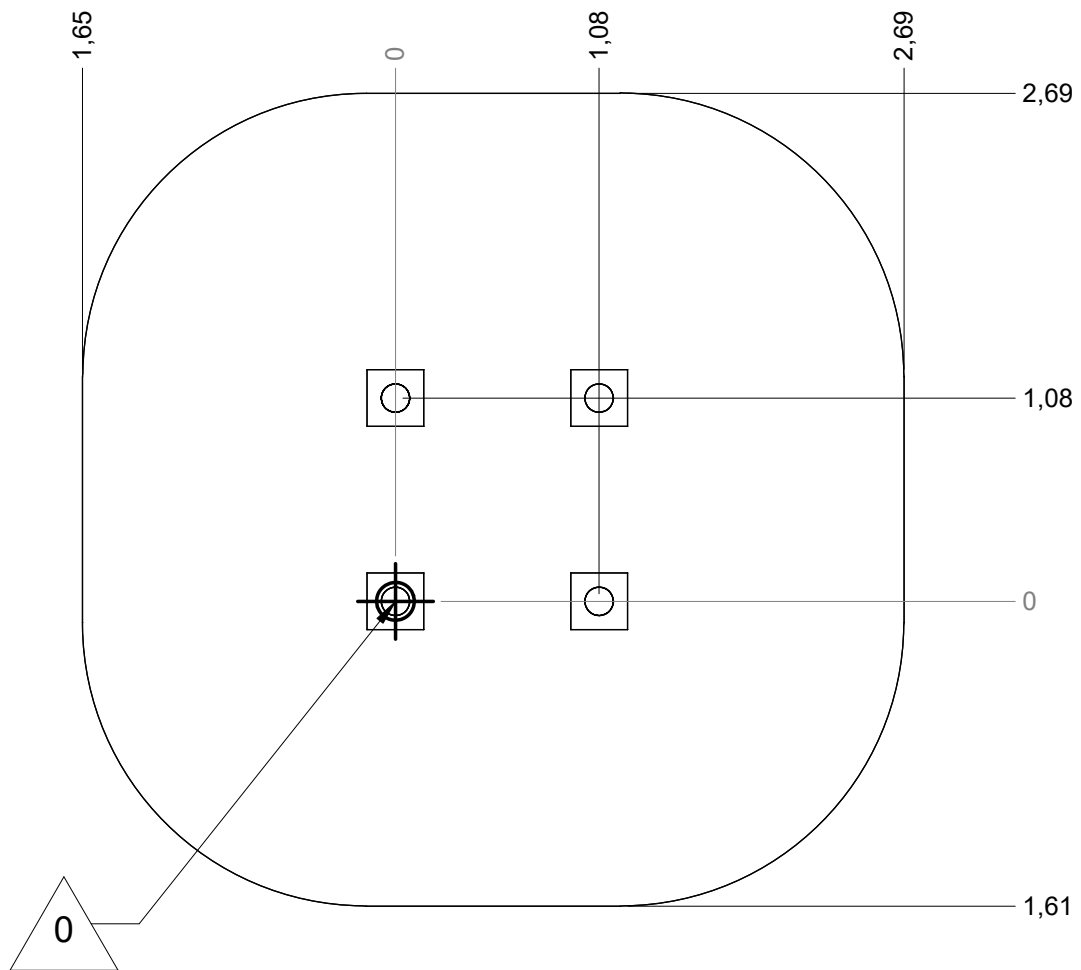

Implantation
 Footing plan
 Implantación
 Fundamentplan
 Funderingstekening

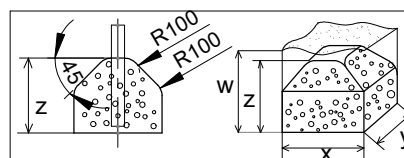

 x2
 2H
 0.12 m³



	x	y	z	w
	0.3	0.3	0.3	0.6
	0.4	0.4	0.3	0.6
	0.6	0.3	0.3	0.6

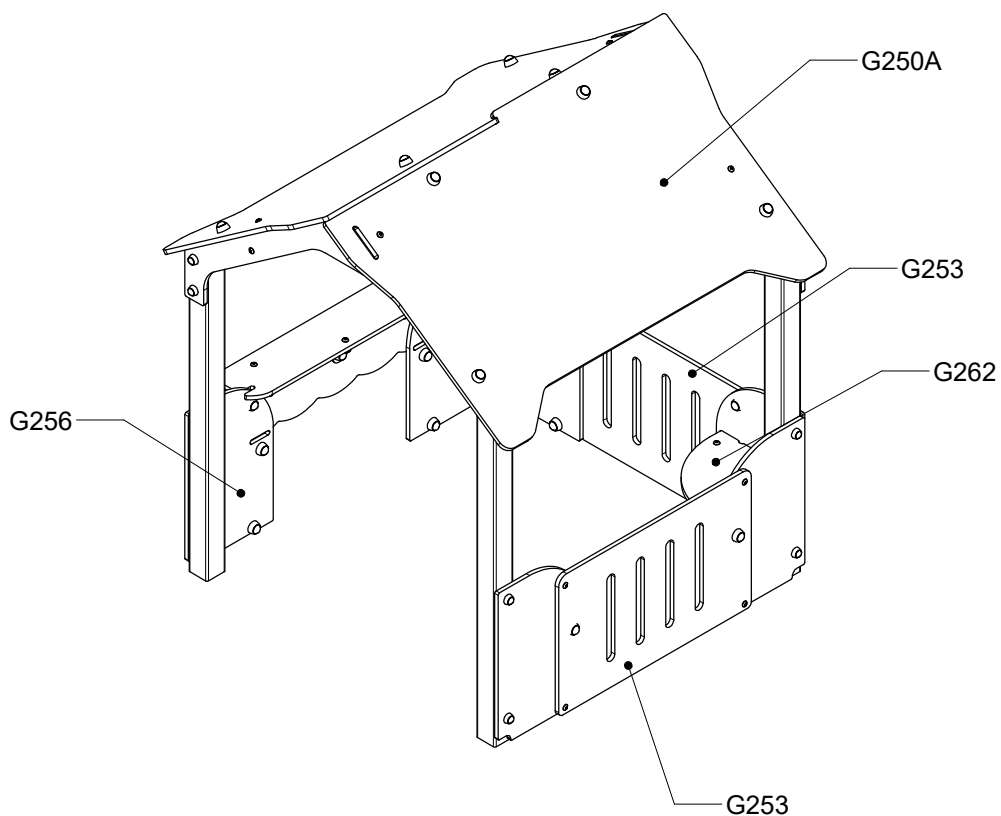

Réf	Qté
G250A	1
G253	2
G256	1
G262	1

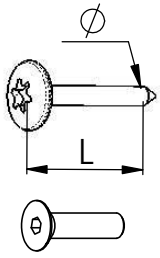

VBT 6 x 30
 \varnothing L (mm)

VFHC

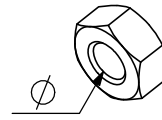

VEC M10
 \varnothing

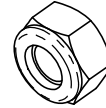

VEF

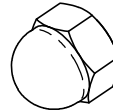

VEB

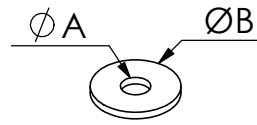

VR6x18
 $\varnothing A$ $\varnothing B$

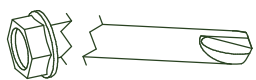

1000 - 1800 RPM
 Vitesse de rotation
 Rotation speed

< 14 N.m
 Couple de rupture
 Breakage torque

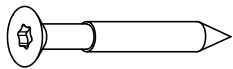

VWT

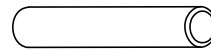

VGC

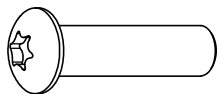

VCBHC

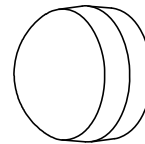

M10 440N

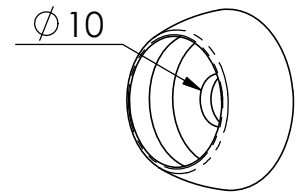

M10 310 N

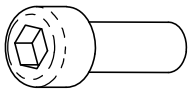

VBTR

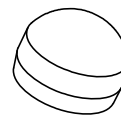

M8440N

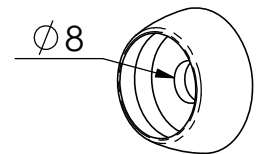

M8310N

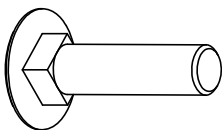

VTRCC

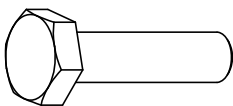

VTH

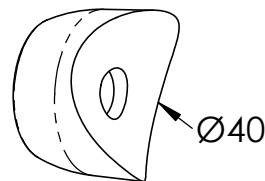

MI2503

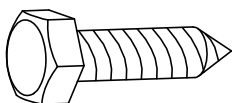

VTF

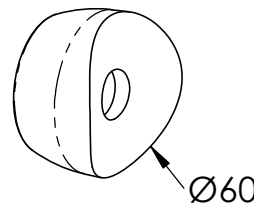

MI2701

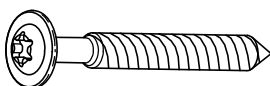

VBT

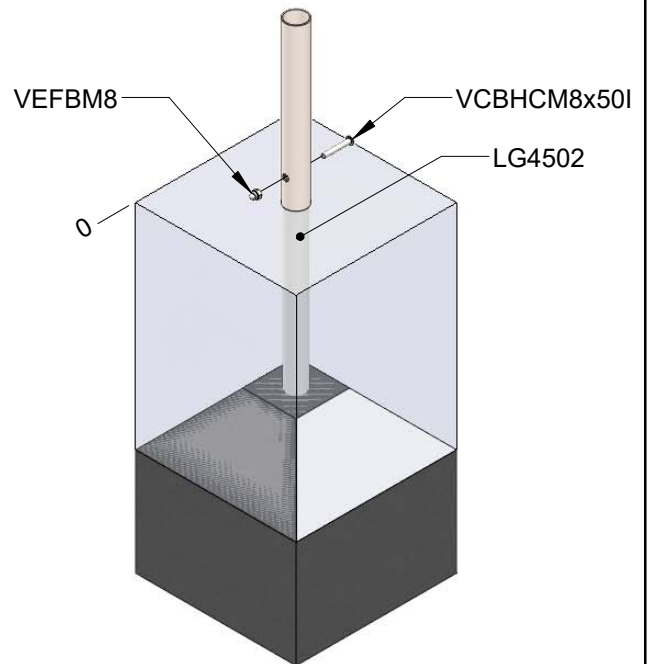
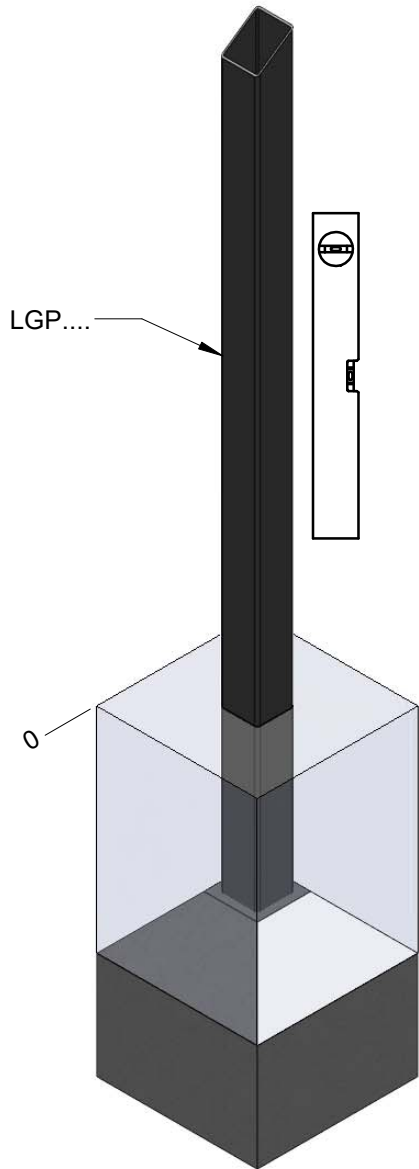

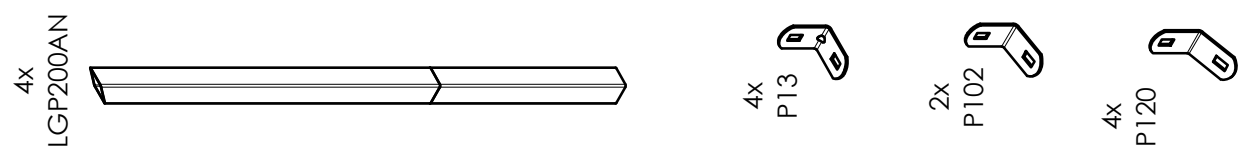
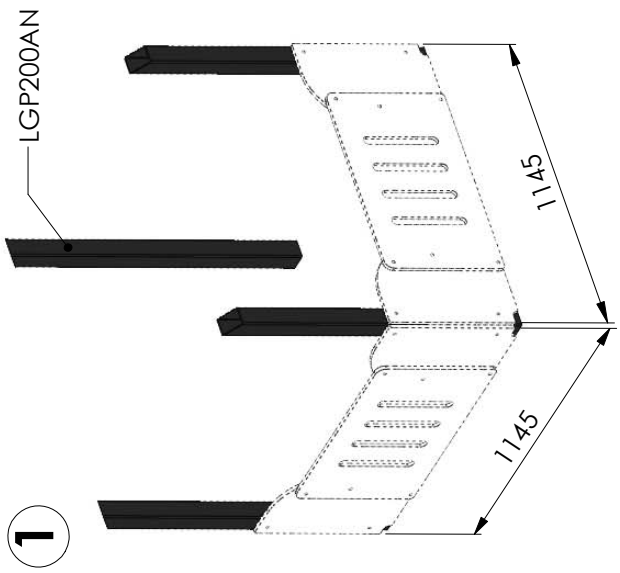

Réf	Qté
ET350VX	2
ET351CH	2
LGP200AN	4
M8310N	8
M8440N	8
M10310N	16
M10440N	16
P13	4
P102	2
P120	4
VCBHC M10x30I	16
VEFM10	16
VTH6x30A	8

2

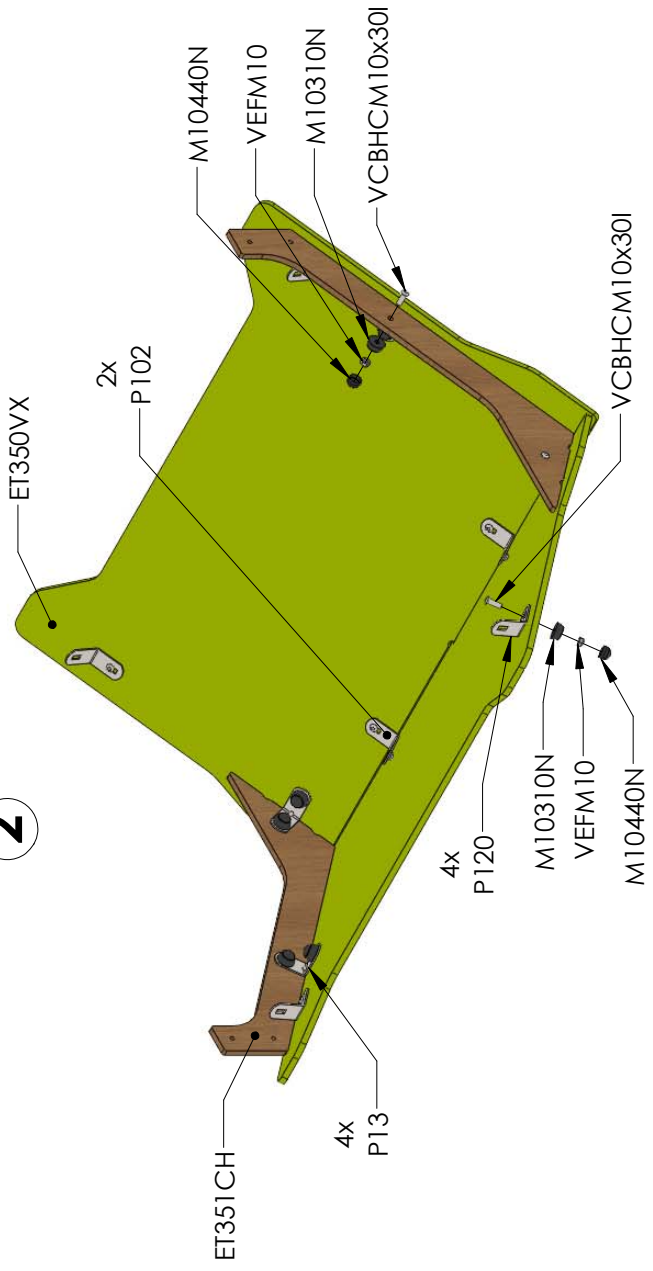

3

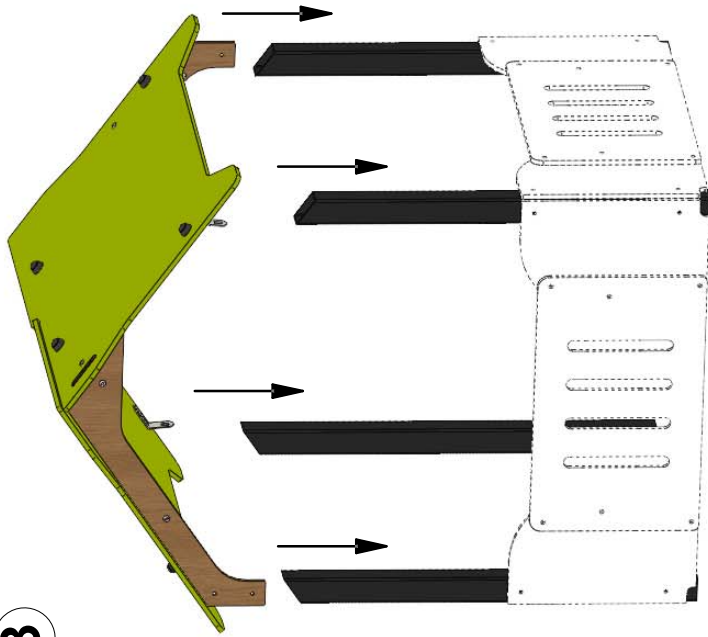

4

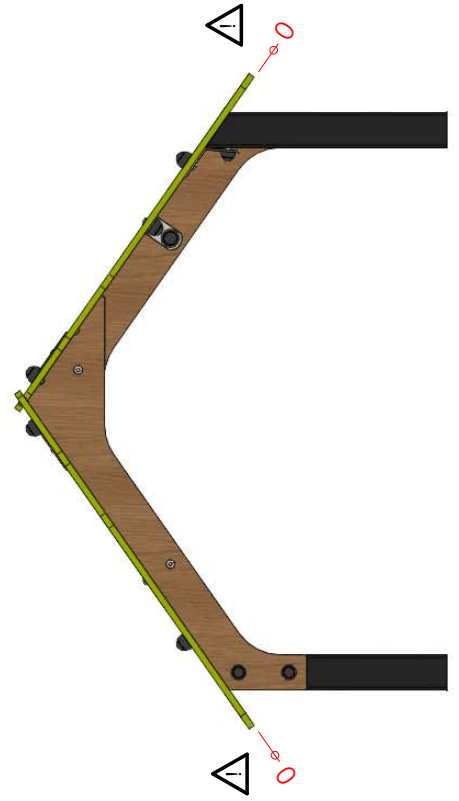
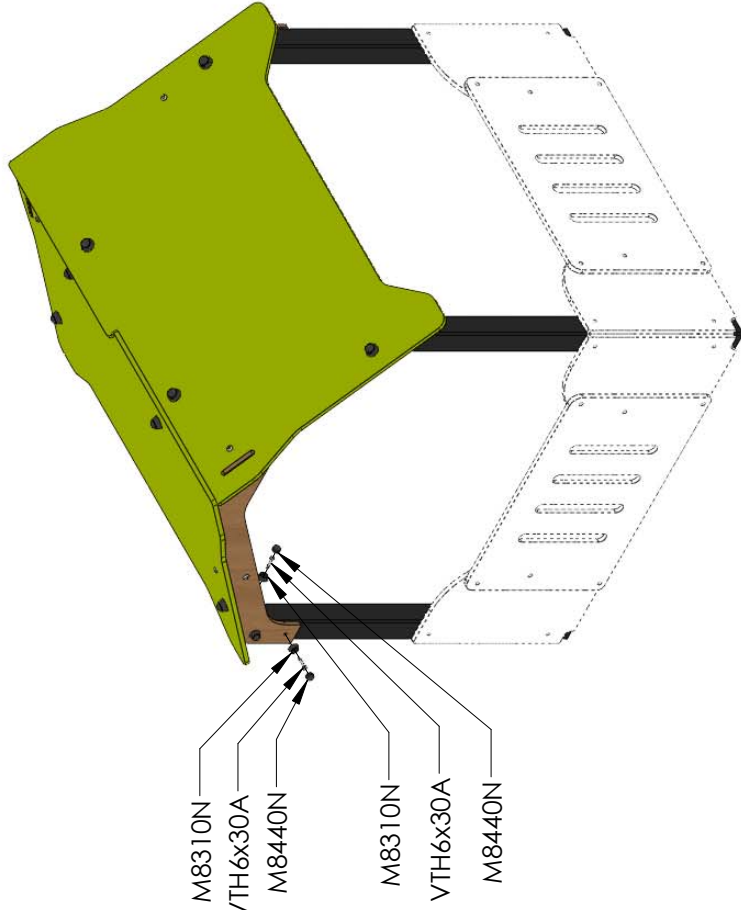

1

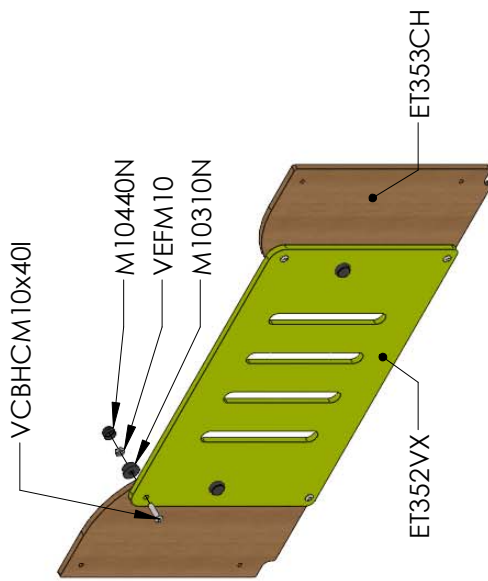

2

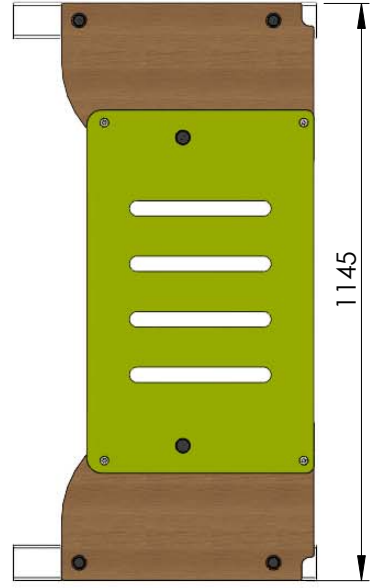
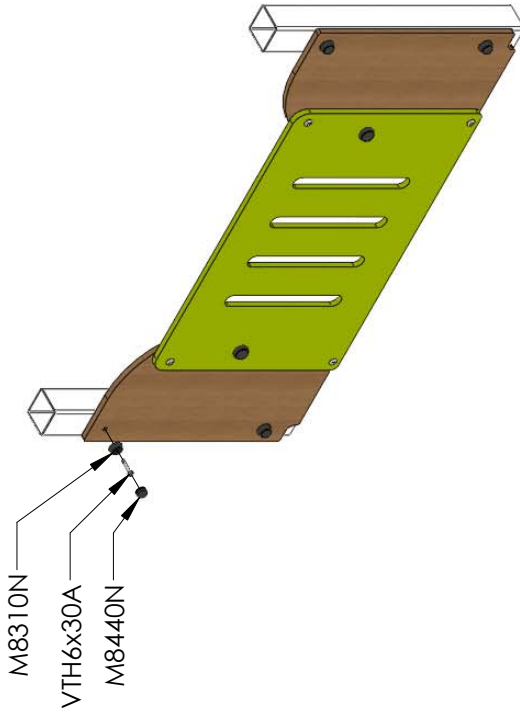

1x
ET352VX

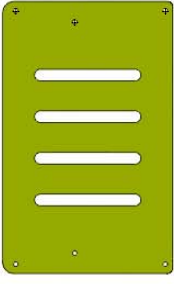

2x
ET353CH

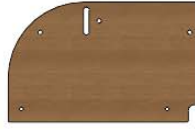

Réf	Qté
ET352VX	1
ET353CH	2
M8310N	4
M8440N	4
M10310N	6
M10440N	6
VCBHC M10x40I	6
VEFM10	6
VTH6x30A	4

1

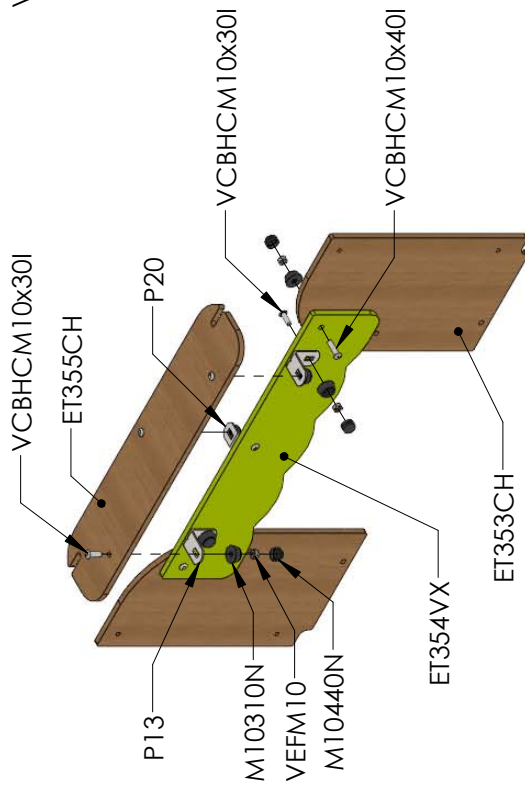

2

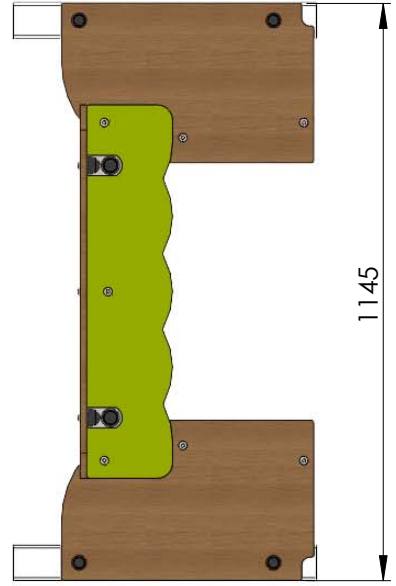
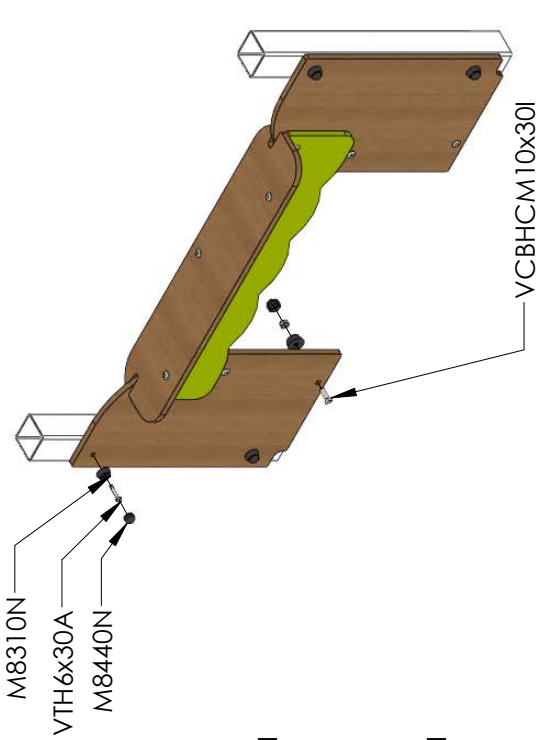

2x
ET353CH

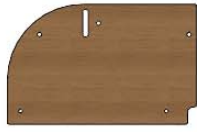

1x
ET355CH



1x
ET354VX



2x
P13



1x
P20



Réf	Qté
ET353CH	2
ET354VX	1
ET355CH	1
M8310N	4
M8440N	4
M10310N	12
M10440N	12
P13	2
P20	1
VCBHC M10x30I	10
VCBHC M10x40I	2
VEFM10	12
VTH6x30A	4

1

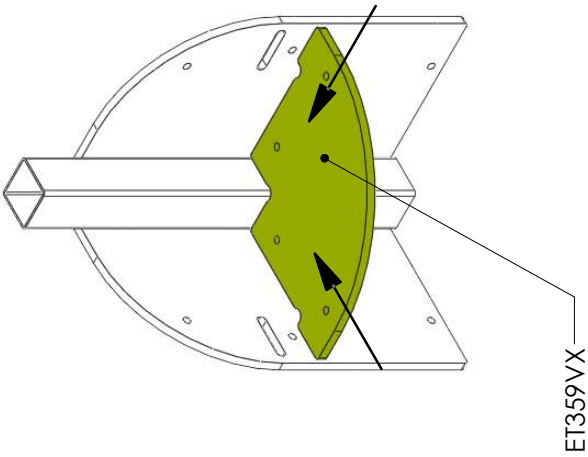

ET359VX

2

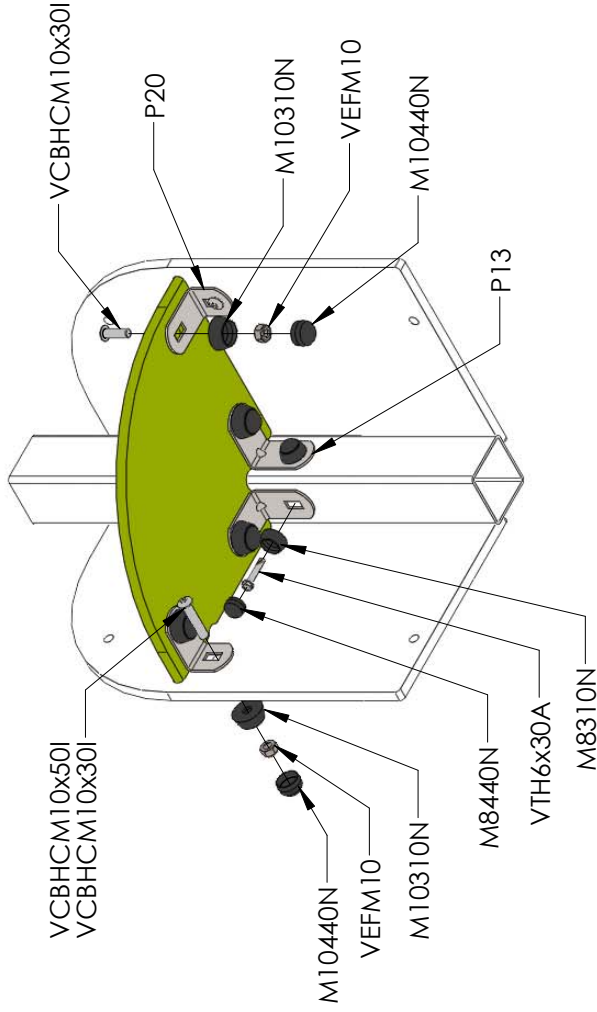

1x
ET359VX

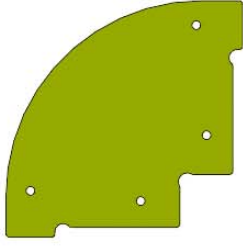

Réf	Qté
ET359VX	1
M8310N	2
M8440N	2
M10310N	6
M10440N	6
P13	2
P20	2
VCBHCM10x30I	4
VCBHCM10x50I	2
VEFM10	6
VTH6x30A	2